

# MIAP6200-2N2-5T

## Industrial DIN-Rail 100M Wi-Fi Wireless AP



- Support 1 100M WAN/LAN multiplexing port, 4 100M LAN ports and 2 2.4GHz antenna Interfaces
- Support five working modes of routing, AP, relay, bridge and client
- Support 802.11k/v/r fast roaming. When wireless roaming terminals move between multiple identical WLANs, they can achieve fast switching, low latency, and smooth transition
- Support WDS wireless and WISP universal bridging to expand and extend wireless signals
- Support firewall and service functions such as port forwarding, IP/MAC speed limiting/filtering, DMZ, QoS, intranet penetration, DDNS, VPN, SNMP, LLDP, etc
- High-strength aluminum alloy casing, IP40 protection level, fanless casing for heat dissipation, the equipment can reliably work in harsh industrial environments of -40°C~+70°C





## Product Description

MIAP6200-2N2-5T is a 5-port 100M Din-rail industrial-grade wireless AP specially designed and developed for industrial communication network applications. It provides 2\*2.4GHz antenna interfaces, 1\*100M WAN/LAN multiplexing copper port and 4 One 100M LAN port Support 1 DC9~36V power input, and adopts the standard DIN rail installation method to meet the needs of various network sites.

The product supports WEB configuration of a variety of network management functions, such as routing/AP/relay/bridging/client mode, universal/WDS bridging, fast roaming, AC control, dynamic/static/PPPoE dial-up networking, IP address conflict detection, DHCP server, IP/MAC binding, radio frequency settings, black and white list, static routing, network diagnosis, firewall, intranet penetration, DDNS, VPN, SNMP, LLDP, NTP, etc.; the system provides user management with different permissions and Support local/remote log management. Support scheduled restart, configuration backup and recovery, firmware upgrade, and factory settings restoration. The hardware adopts high-standard industrial protection design, with selected industrial-grade components and high-strength aluminum alloy casing, which is sturdy and durable; low power consumption, wide temperature design, fanless casing heat dissipation, Support -40°C~+70°C Operating temperature, and passes Strict safety regulations and EMC testing meet the application requirements of harsh industrial environments. Products can be widely used in industrial automation, integrated energy, smart cities, smart transportation, smart mines, smart factories and other fields.



## Features and Benefits

- Support routing mode, WAN can be connected to the external network through DHCP/static address/PPPoE dial-up mode, realizing wired and wireless terminal networking
- Support AP mode, which can convert the wired network into a wireless network, allowing wireless terminals to access the wired network, and the AC is controllable
- Support relay mode, which can amplify the upper-level wireless network, convert the wireless network into a wired network, and realize wired and wireless terminal access
- Support bridge mode, which can convert wireless networks into wired and wireless networks to achieve wired and wireless terminal access
- Support client mode, which can convert the wireless network into a wired network and enable wired terminals to access the wireless network
- Support IP address conflict detection, quickly locates the source of IP conflicts and avoids network failures
- Support DHCP server to centrally dynamically manage and configure user IP addresses
- Support DHCP access device management, binding client IP and MAC address to avoid IP address changes or conflicts
- Support 802.11k/v/r fast roaming, reduces the number of information interactions through FT protocol, achieves low latency, and improves user Internet experience
- Support multiple country code switching, suitable for channels in different regions
- Support transmission power adjustment, limit on the number of connected users, SSID hiding, user isolation, WDS bridging, etc.
- Support WEP-OPEN/SHARE-AUTH, WPA/WPA2-PSK encryption methods, CCMP, and TKIP encryption algorithms
- Support wireless user management, black/white list can filter wireless users, prohibit/allow designated wireless users to access
- Support static routing, which can accurately control network routing selection, improve network performance, and ensure network bandwidth.
- Support IPv4/IPv6 Ping, IPv4/IPv6 Traceroute, Nslookup, and packet capture for network diagnosis or fault analysis
- Support SYN-flood defense, port forwarding, IP/MAC/DNS address filtering, iptables command custom rules, DMZ isolation zone, UPnP, IP/MAC network speed control, QoS services and other firewall functions
- Support NTP client and server functions, can perform clock synchronization or provide clock source
- Support hierarchical management of user rights and SSH, HTTP/HTTPS access control
- Log information records multiple levels of kernel, application and network information, and Support local downloading, scheduled saving, and remote monitoring.
- Support Peanut Shell intranet penetration, and can use Peanut Shell dynamic domain name to remotely log in and manage equipment
- Support dynamic DNS function, and can remotely log in and manage the device through the specified domain name
- Support VPN client and server to build a dedicated network. The client Support tunnel protocols such as

PPTP, L2TP, IPSec, OpenVPN, and GRE. The server Support protocols such as PPTP, L2TP, and IPSec

- Support SNMPv1/v2c and SNMP Trap. Information query, information modification and troubleshooting can be carried out through MIB to achieve centralized management.
- Support LLDP, obtains LLDP neighbor device information, and monitors link status to facilitate topology management and fault location.
- AP mode Support quick discovery of ACs on Layer 2 and Layer 3 networks, and automatic registration and online functions
- AP mode Support AC controller wireless radio frequency parameter configuration and entire network management functions
- AP mode Support automatic synchronization of configuration parameters when online, and periodically reports device and wireless terminal information
- AP mode Support AC controller wireless black and white list configuration function
- AP mode Support fast roaming function under AC controller to realize roaming switching function of wireless terminal equipment
- AP mode Support multiple upgrade methods such as single upgrade, batch upgrade, online and online automatic upgrade under the AC controller
- AP mode Support wired or wireless rescue network. When the network is abnormal, access the fixed IP through the wired or wireless network to log in to the WEB management device

## Specification

### Software

Network Management Function	<p>Support traffic statistics, operating status, network status, local address and other status information or wireless information</p> <p>Support routing mode, AP mode, relay mode, bridge mode, client mode</p> <p>Support static address, DHCP, PPPoE external network connection</p> <p>Support DHCP server, IP/MAC binding, wireless user black and white list</p> <p>Support IP address conflict detection</p> <p>Support 802.11k/v/r fast roaming</p> <p>Support static routing</p> <p>Support peanut shell intranet penetration, dynamic DNS, SNMP, LLDP</p> <p>Support PPTP/L2TP/GRE/TUN/TAP protocol VPN client</p> <p>Support PPTP/L2TP/IPSec protocol VPN server</p>
Firewall	<p>Support SYN-flood defense, IP dynamic camouflage, MSS clamping, inbound/outbound data control</p> <p>Support WAN/LAN port TCP/UDP port mapping</p> <p>Support IP/MAC/domain name filtering, iptables, DMZ, UPnP, IP/MAC/QoS rate limiting</p>
System Management	<p>Support IPv4/IPv6 Ping, IPv4/IPv6 Traceroute, Nslookup, and capture network packets</p> <p>Support time zone, NTP client/server, Crontab, remote/local log</p> <p>Support user rights management, SSH, HTTP/HTTPS access control</p> <p>Support online restart, scheduled restart, configuration backup/restore, firmware flash, and factory settings restore</p>

### Wi-Fi

Wireless Standards	2.4GHz 802.11b/g/n
Frequency range	2.412GHz~2.484GHz
Band Bandwidth	20MHz/40MHz
Theoretical Transfer Rate	2.4GHz: 300Mbps
TX Power	<p>IEEE 802.11n: 13-16dBm @HT20/40 MCS7</p> <p>IEEE 802.11g: 14-17dBm @54MHz</p> <p>IEEE 802.11b: 16-19dBm @11MHz</p>
RX Sensitivity	<p>HT40 MCS7: -69dBm@10% PER(MCS7)</p> <p>HT20 MCS7: -71dBm@10% PER(MCS7)</p> <p>54M: -75dBm@10% PER</p> <p>11M: -88dBm@ 8% PER</p>

### Interface

100M WAN	1*10/100Base-T(X) auto-sensing 100M WAN/LAN multiplexing port, using RJ45, supporting full/half duplex, auto MDI/MDI-X
----------	--

Specification	
100M LAN	4*10/100Base-T(X) auto-sensing 100M LAN ports, using RJ45, supporting full/half duplex, auto MDI/MDI-X
Antenna Connector	2*2.4GHz antenna Interface, using SMA-K (external thread internal hole)
Status LED	Power indicator, operation indicator, WiFi indicator , interface indicator
Power Supply	
Input Voltage	DC9~36V
Full load power consumption	<2.5W@DC12V
Connection	5.08mm pitch 2-PIN terminal block
Physical Characteristics	
Dimension	118×35×88(mm)(excluding rails)
Installation	Easy installation on 35mm DIN rails
IP Code	IP40
Weight	About 0.35kg
Working Environment	
Operating Temperature	-40°C~+70°C
Storage Temperature	-40°C~+85°C
Relative Humidity	5%~95% (non-condensing)
Industry Standard	
EMC	IEC 61000-4-2 (ESD) : Level 4 IEC 61000-4-5 (Surge) : Level ※The network port supports 6kV lightning protection IEC 61000-4-4 (EFT) : Level 4
Certification	CE, FC, RoHS, CCC



Dimensions

Unit:mm

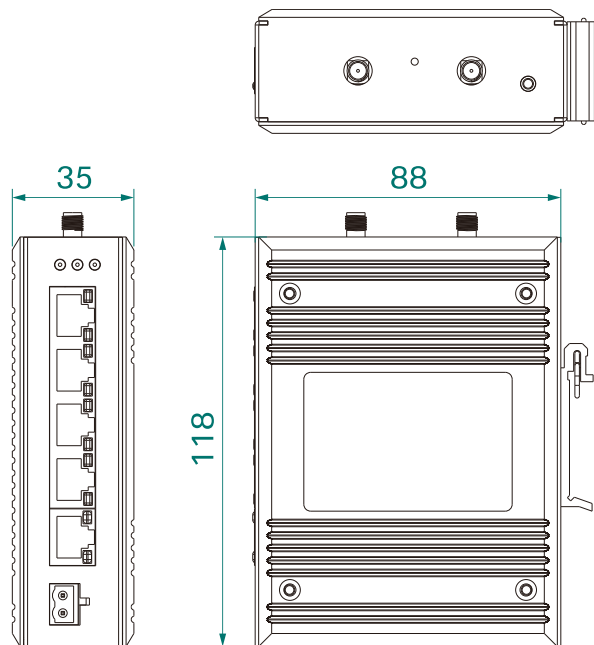



## Ordering Information

Standard Model	100M WAN Port	100M LAN Port	2.4GHz antenna	Input Voltage
MIAP6200-2N2-5T	1	4	2	DC 9~36V



## Contact Us

### **Wuhan Maiwe Communication Co., Ltd**

Address: No.52 Liufang Avenue, East lake High-tech Development Zone, Wuhan, China.

Tel: 027 8717 0217

Mail: [enquiry@maiwe.com](mailto:enquiry@maiwe.com)

Official site: [www.maiwe.com](http://www.maiwe.com)

Copyright © Maiwe Communication All rights reserved.